



Instruction Manual

■ Paint Tank

PT-10D · 10DW · 10DM · 10DMW

PT-20D · 20DW · 20DM · 20DMW

PT-40D · 40DM · 40DMW

PT-60D · 60DM · 60DMW

PT-80D · 80DM · 80DMW

This instruction manual includes important warnings, cautions and operations. Before use, be sure to read this instruction manual fully. Keep this instruction manual in an appropriate place for immediate reference.

■ Important information

- This product is exclusively used for coating. Do not use for other purposes than coating.
- Be sure to read and understand this instruction manual fully. The operator shall be fully conversant with the requirements stated within this instruction manual including important warnings, cautions and operations.
- Wrong operation (mishandling) can cause serious bodily injury, death, fire or explosion.





Keep this instruction manual in an appropriate place for immediate reference.



● Safety factor

- Safety precautions in this instruction manual are minimum requirements. Observe other regulations about electricity, safety and fire fighting designated by your country, local government and your company.
- Pay special attention to items which are shown by the below marks and symbols.
- Marks and symbols mean as follows:

Marks of warnings and cautions



 WARNING	Indicates a potentially hazardous situation which, if not avoided, may result in serious injury or loss of life.
 CAUTION	Indicates a potentially hazardous situation which, if not avoided, may result in minor or moderate injury or property damage.

Examples of symbols

	Indicates [you must be careful]. We will explain briefly in or near the symbol. (Example on the left is [be careful about ventilation]).
	Indicates [you must not do]. We will explain briefly in or near the symbol. (The example on the left is [do not touch]).
	Indicates [you must do]. We will explain briefly in or near the symbol. (The example on the left is [be sure to wear protective gear]).

※We shall not be responsible for any injury or damage caused by disregard of warnings, cautions or instructions.

● Supplementary notes

	Indicates notes which we ask you to observe. They are helpful to achieve full performance and function of the equipment.
	Indicates helpful knowledge or advice.



Important information

- 1. Safety precautions ····· 2
- 2. Check the products ····· 3
- 3. Specifications ····· 4
- 4. Name of each section and function ·· 5
- 5. Installation ····· 7
- 6. Operation ····· 7
- 7. Maintenance ····· 11
- 8. Problems and remedies ····· 12
- 9. Parts list ····· 14

1. Safety precautions

WARNING

Wear protective gear.

During painting, be sure to wear protective gear such as glasses, mask or gloves. Paints or solvents might enter your eyes or you might inhale them. If you feel any abnormality during operation, immediately see a medical doctor.



Be careful about ventilation.

- Use it in a well-ventilated place. Painting or cleaning in a narrow place with insufficient ventilation can cause organic solvent poisoning by sprayed mist of paint or volatile solvent. If you feel any abnormality during operation, immediately see a medical doctor.
- Sprayed mist of paints or solvents can catch fire, causing fire or explosion, which is very dangerous.



Danger caused by wrong operation of equipment

- Never use in another way than to apply pressure for paint transfer. If done, it can cause insufficient performance or failure.
- Do not use with corrosive liquids (halogenated hydrogen carbon, oxygen, alkaline). If done, corrosion can cause failure. If you consider use of a special cleaning solvent, we are ready to supply you with a material list of our paint tank on request.
- Never point paint (gun) toward a person or animal, or put your finger in front of tip of air cap. If done, paint can enter human body directly through eyes, mouth or skin. It is very dangerous.



Keep away from origins of explosion or fires.

- Never use near sparks or open fire. Especially the following will cause fire. It is very dangerous.
 - Open flames such as cigarettes or pipes
 - Electric goods such as stoves, lamps or heaters



Contact is forbidden.

- In the case of an automatic agitating system (model with air motor), never try to touch shaft of air motor or turning section. If done, it can suddenly start and your hand can get tangled.



Contact grounding.

- Securely ground pump, spray gun, workpieces and containers containing paints or solvent. Insufficient grounding will cause explosions or fire if exposed to a spark of static electricity.



Be careful about explosion of fluid hose.

- Never bend hose with a radius of less than 50mm. Never put heavy things on it. If done, hose can explode, causing great danger.
- Securely connect hose to avoid leak and looseness. If hose is disconnected during operation, hazardous hose movement and paint ejection will cause severe bodily injury.
- Never use the following hoses. Such a hose can cause great danger during operation. It is very dangerous.
 - cracked
 - bent
 - damaged
 - crushed or distorted



WARNING

Be careful about explosion.

- Be sure to use it at less than maximum fluid operating pressure.

If done, it can cause damage to the paint tank or emission of paint or flying parts, resulting in serious bodily injury.

- Never remove safety valve or alter setting figures.

If done, it makes it difficult to deal with emergencies, resulting in explosions or accidents.

- Be sure to release pressure in paint tank before inspecting or cleaning inside of paint tank.

If not done, it can cause serious bodily injury through eruption of paint or flying parts.

Before maintenance or inspection, be sure to release compressed air in paint tank and make sure by checking pressure gauge that there is no pressure remaining in the paint tank. If you do

maintenance or inspection while pressure remains in tank, parts being disassembled can fly out and cause injury.



Important

- Never alter the paint tank.
- Be sure to use our genuine parts when you make repairs or replace parts. If not, it can cause insufficient performance or failure.

■ 2. Check the products

- Check to make sure that the products are as ordered and that the products have not been distorted or damaged.

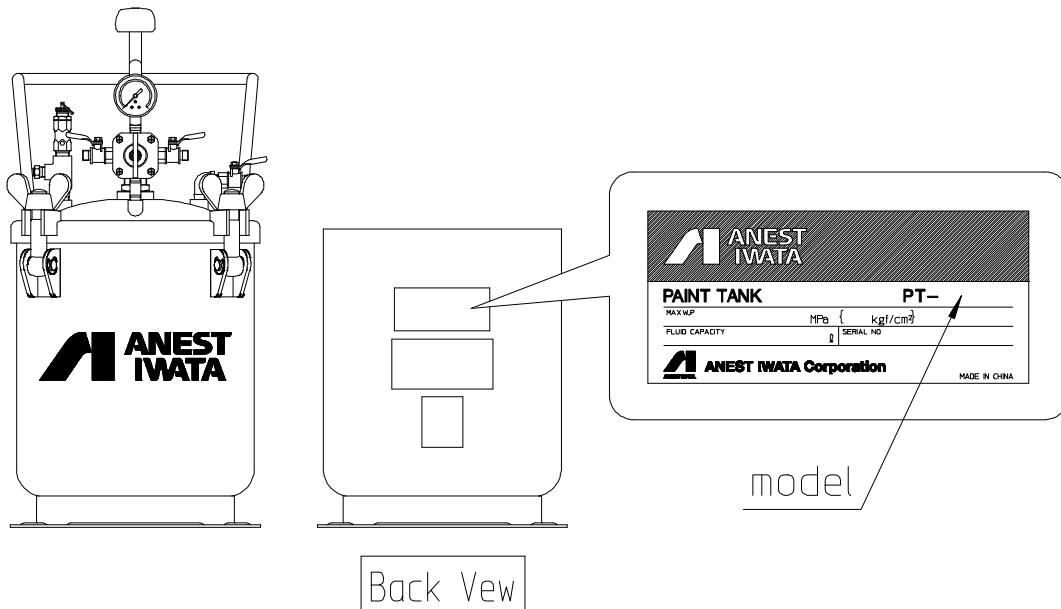

Check the accessories.

Check that accessories have been included.

©instruction manual

Where to attach warning stickers

Always keep warning labels clean. If they become dirty or damaged, replace them with new ones. If you need new stickers, contact the shop which sold the product to you.

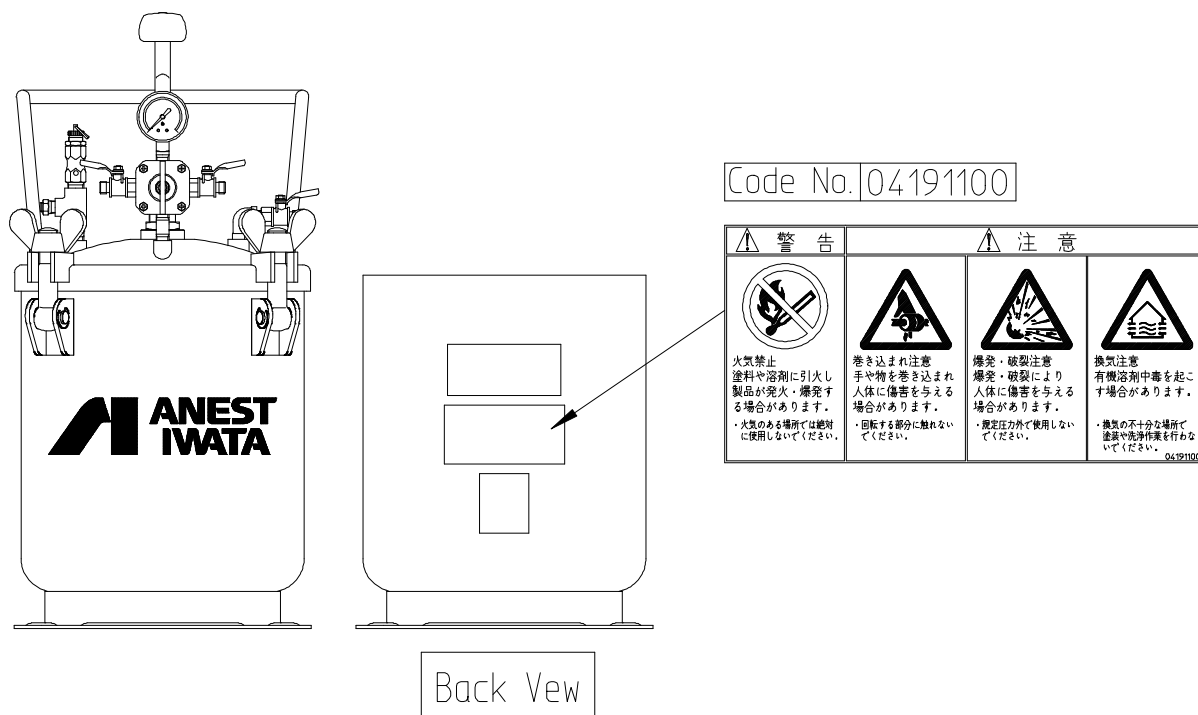

3. Specifications

Items	PT-10 D(W)	PT-20 D(W)	PT-40 D	PT-60 D	PT-80 D	PT-10 DM(W)	PT-20 DM(W)	PT-40 DM(W)	PT-60 DM(W)	PT-80 DM(W)	
Agitating system	manual agitation					automatic agitation					
Tank capacity (L)	10	20	40	60	80	10	20	40	60	80	
Max. operating air pressure MPa {kgf/cm ² }	0.34 {3.5}		0.18 {1.9}			0.34 {3.5}		0.18 {1.9}			
Air inlet	G 1/4										
Fluid outlet	G 3/8×1		G 3/8×2			G 3/8×1		G 3/8×2			
Dimen-si ons, mass	H mm	547	652	700	885	1045	485	590	648	828	1000
	L mm	370	390	465	465	465	370	390	465	465	465
	W mm	315	330	460	500	500	315	330	460	500	500
	Mass kg	12.7	19.5	27	35	38.5	13.5	23	30.5	37.5	42
Air motor model	—	—	—	—	—	AM-5C	AM-3C				
Safety valve	SVB-8-35		SVB-8-19			SVB-8-35		SVB-8-19			
Air regulator	RR-56B										
Ambient temperature range	5~40°C										

■ 4. Name of each section and function

Paint tank feeds paint in paint tank by pressure which is adjusted by an air regulator.

PT-20D(W)(manual agitating system)

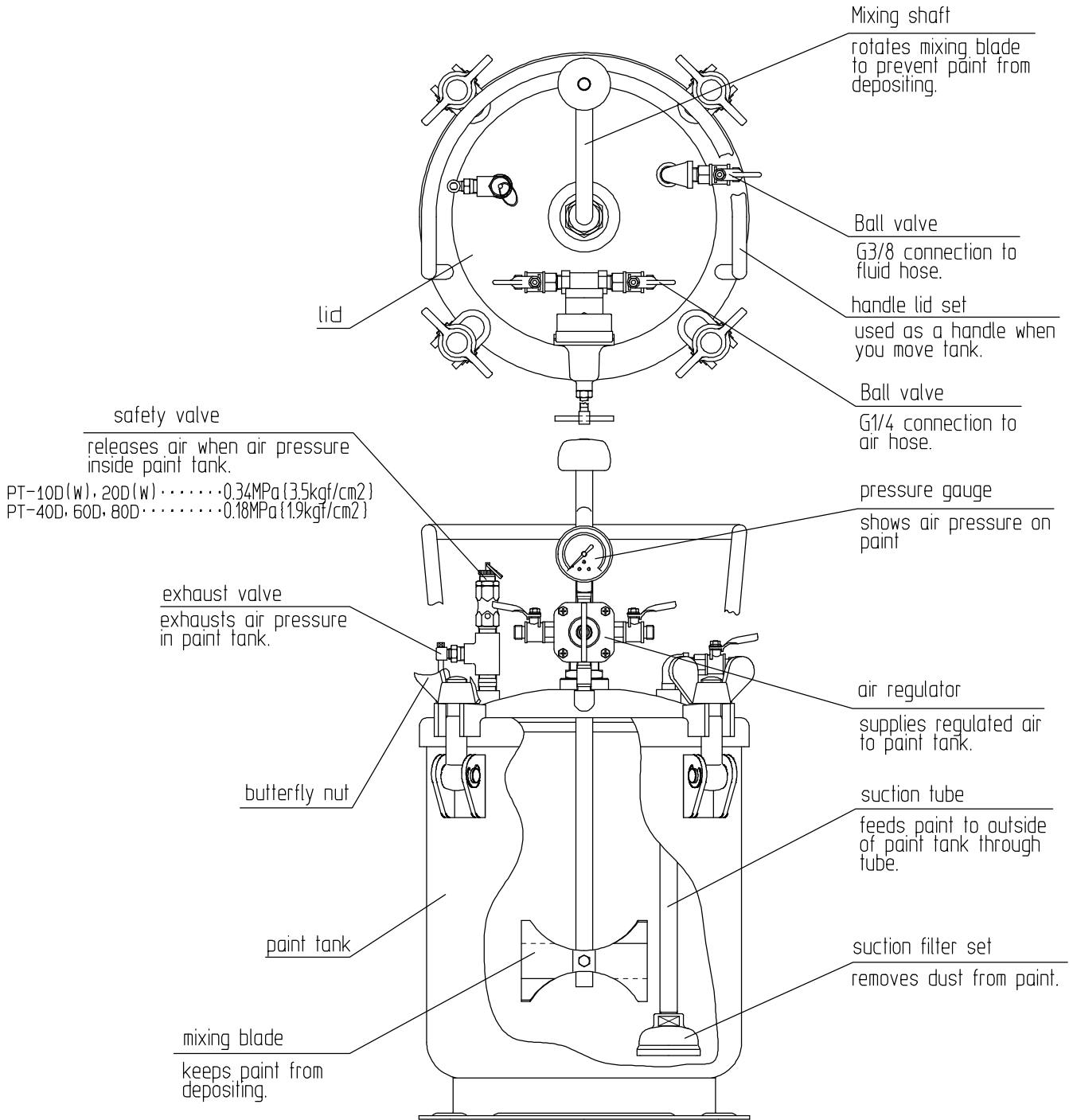

PT-20DM(W) (automatic agitating system)

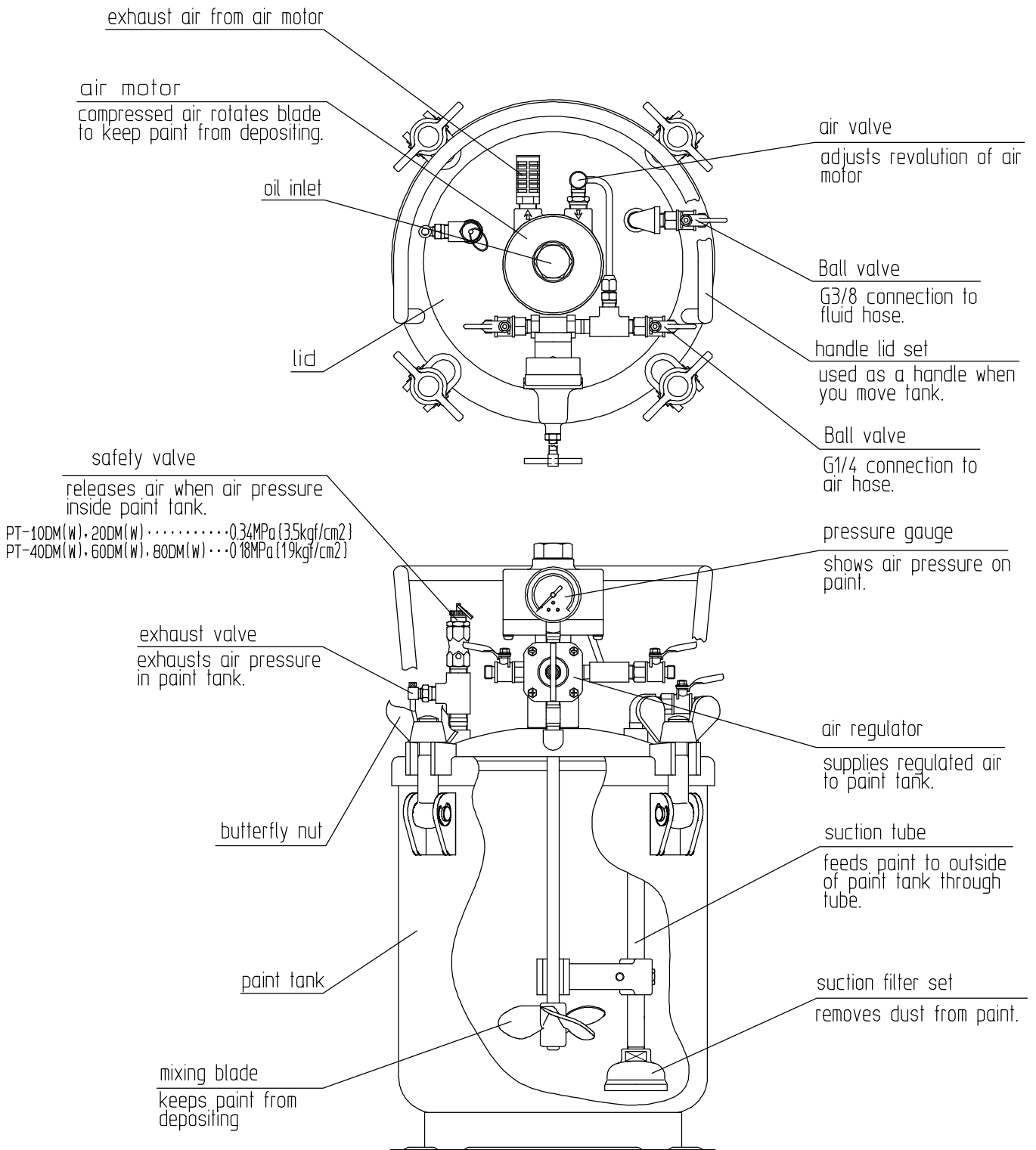

■ 5. Installation

Important

- It can cause an unpredictable accident if paint tank suddenly moves or topples.

Job 1

Install paint tank on a horizontal surface so that it does not move.

Job 2

Securely connect air hoses to inlet and outlet sides and fluid hose.

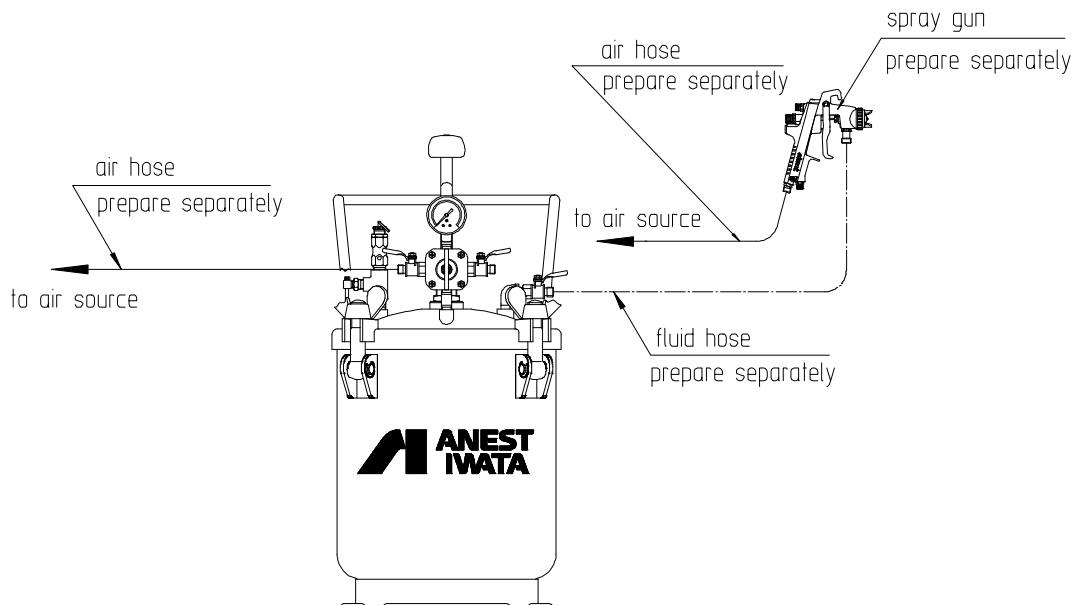

■ 6. Operation

6-1. Preparation

⚠ CAUTION



Be sure to release compressed air before you lift handle lid set and inspect the inside.
If not done, flying parts can cause serious injury.

Job 1

Open exhaust valve and release compressed air.

If you loosen butterfly nut while compressed air remains in paint tank, flying parts or paint can cause serious injury or accidents.

Job 2

Close air valve and stop air motor.

(This is not necessary in the case of manual agitating type PT-10D(W), 20D(W), 40D, 60D and 80D)

Job 3

Loosen butterfly nut, lift handle lid set and inspect the inside of paint tank.

If the inside has become dirty, clean it and pour paint which is filtered.

Job 4

Close handle lid set and securely tighten butterfly nut.

Tighten it evenly.

Job 5

Securely connect air hose to air hose connection, and fluid hose to fluid hose connection.

Job 6

Close exhaust valve.

Job 7

Open oil cap (screw) of air motor and pour in grease. After supplying grease, securely close oil cap. (This is not necessary in the case of manual agitating type PT-10D(W), 20D(W), 40D, 60D, and 80D.)

6-2. Start-up operation and adjustment

WARNING



• **Never remove safety valve or alter setting figures.**

If done, safety valve cannot deal with emergencies, resulting in an explosion or accident.

• **If shaft of safety valve becomes dirty, clean it and apply oil.**

Dirty shaft can cause failure, explosion or accident.

If it is damaged or bent, you must ask a specialist to repair it.

Safety valve has been adjusted to operate as follows:

0.34MPa {3.5kgf/cm²} for PT-10D(W), 10DM(W), 20D(W), 20DM(W)

0.18MPa {1.9kgf/cm²} for PT-40D, 40DM(W), 60D, 60DM(W), 80D, 80DM(W)

Job 1

Agitate paint.

Turn agitating shaft manually for manual agitating types PT-10D(W), 20D(W), 40D, 60D and 80D. In case of automatic agitating types PT-10DM(W), 20DM(W), 40DM(W), 60DM(W) and 80DM(W), open air cock and gradually open air valve to operate air motor.

Job 2

Open air cock (already operated in above **Job 1**) as for automatic agitating type).

Gradually tighten air regulator handle to get necessary pressure. If pressure becomes too high, loosen air regulator handle. Air release valve fitted to air regulator automatically releases air pressure in accordance with loosened value. Readjust and fix it after pressure becomes stable.

Job 3

Open fluid cock.

Job 4

Test spray

During spray test, fully adjust both fluid pressuring air pressure and atomizing air pressure.

Relationship between fluid pressurizing pressure and atomizing air pressure

Hint!

The relation will have a great influence on job productivity and coating finish. In general, test spray at fluid pressurizing air pressure of 0.05MPa {0.5kgf/cm²} and gradually change atomizing air pressure to get optimal condition.

【Standard pressure】

Kind of paints	Fluid pressurizing air pressure	Atomizing air pressure
Low viscosity	0.03~0.07MPa {0.3~0.7kgf/cm ² }	0.25~0.39MPa {2.5~4.0kgf/cm ² }
High viscosity	0.10~0.15MPa {1.0~1.5kgf/cm ² }	0.29~0.54MPa {3.0~5.5kgf/cm ² }

When fluid hose is long or spray gun position is higher than paint tank, adjust air pressure slightly higher than the above.

【Influence on coating finish】

- ① If you decrease fluid pressure and increase atomizing air pressure, spray mist becomes finer and coating finish becomes smoother.
- ② If you go too far in above ①, fluid output becomes too small, resulting in “orange peel”.
- ③ If you increase fluid pressure and decrease atomizing air pressure, fluid output becomes larger and job productivity increases, however, spray mist becomes coarse.
- ④ If you go too far in above ③, coating finish becomes rough and causes sags or tails.

Job 5

After spray test, start normal coating job.

6-3. End of operation

Job 1

Close air valve and stop air motor (this is not necessary for manual agitating type PT-10D(W), 20D(W), 40D, 60D and 80D)

Job 2

Close air cock, open exhaust valve to release compressed air pressure in paint tank.

Job 3

Fully return air regulator handle (Air release device fitted to air regulator releases air from lower section of handle but this is not a failure)

Job 4

Remove handle lid set and take out paint in container.

Job 5

Securely tighten handle lid set, feed compressed air into paint tank and exhaust paint in fluid hose.

Job 6

After exhausting paint, close ball valve at air inlet again and turn it to the left till handle movement of air regulator becomes light.

Job 7

Clean inside of paint tank which is in contact with paint.

6-4. Precautions during operation

WARNING



- **As safety valve has been adjusted during assembly at plant, do not readjust it.**
If done, it can cause pressure to become higher than necessary and become dangerous.
- **Dirty safety valve fails and can also be dangerous. Pay special attention to this point.**
Safety valves for PT-10D(W), 10DM(W), 20D(W) and 20DM(W) have been adjusted to operate at 0.34MPa {3.5kgf/cm²} and the others for PT-40D, 40DM(W), 60D, 60DM(W), 80D and 80DM(W) have been adjusted to operate at 0.18MPa {1.9kgf/cm²}.
- **Be sure to release air pressure in paint tank before replenishing paint.**
If not done, parts can fly and paints scatter, which is very dangerous.

CAUTION



- **Be sure to filter air through air filter and supply clean air without moisture and oil to paint tank.**
If not done, air including moisture and oil can fail paint finish.
- **Do not touch shaft or turning section of air motor in the case of automatic agitating type.**
If done, it can operate abruptly and cause injury.

Important

- **Do not increase air motor speed abruptly.**
Sudden high speed of air motor can engulf air by agitation and enter air bubble into paint causing sputtering. It can also cause abnormal friction and shorten lifetime of air motor.
(You do not need to worry about manual agitating types PT-10D(W), 20D(W), 40D, 60D, 80D in this respect.)
- **Do not fill paint tank to more than 80% of its capacity.**
If done, paint sticks to lid during transportation or agitation, damages rubber valve of air regulator or reverses flow of paint.

- 1) When using paint which settles easily, turn manual agitator to avoid settlement of paint or adjust automatic agitator speed to make it a bit faster than usual.
- 2) Overtightening of air regulator handle can damage the diaphragm in air regulator. Operate it slowly and loosen it when not in use.

3) When you need an inner container, order it. But a common 18 liter drum can be used as an inner container for PT-60D, 60DM(W), 80D and 80DM(W). In that case, change position so that turbulent plate is inside tank.

4) Replenish paint through paint inlet.

As PT-10D(W), 10DM(W), 20D(W) and 20DM(W) are not equipped with paint inlet, remove lid and replenish paint.

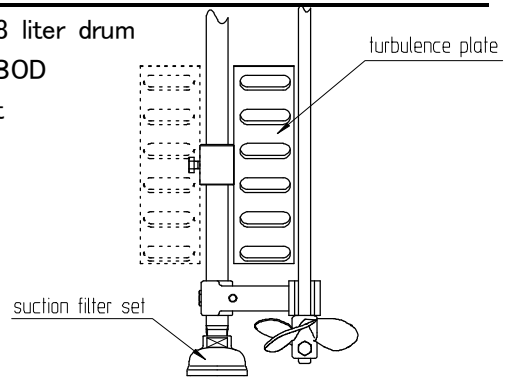

7. Maintenance

WARNING



• When disassembling, be sure to tighten air cock and turn handle of air regulator counterclockwise, and tighten it completely.

If not done, pressure can cause parts to fly and paint to scatter, causing serious bodily injury.

• Refer to the following table and do the inspection and maintenance.

No.	Period	Contents of inspection and maintenance				
1	Daily inspection to air source	<p>① Check cleanliness of safety valve and shaft operation.</p> <ul style="list-style-type: none"> • Clean if appearance is dirty. • Pull ring of top of safety valve and check if shaft moves up and down. • If safety valve fails, ask a specialist to repair it. <p>② Check motion of pressure gauge pointer and any damage to glass. Replace if necessary.</p> <ul style="list-style-type: none"> • Check if pointer returns to 0 position when pressure is not put. • Check if pointer moves up gradually when you put pressure gradually. • Check to make sure that glass is not broken. 				
2	Periodic inspection	<p>① Check daily to see if air intake filter is clogged or damaged. Inspection period depends on the kind of paint to be used.</p> <p>② Clean paint tank fully after use. Clean especially suction tubes, fluid cocks and fluid hoses with solvent.</p> <p>③ Lubricate air motor according to the table below.</p> <table border="1" style="margin-left: 20px;"> <tr> <td>grease</td> <td>supply period</td> </tr> <tr> <td>grease</td> <td>every 1,200 operating hours</td> </tr> </table> <p>④ Visually check inside and outside of the unit.</p> <ul style="list-style-type: none"> • any deformation and crack of tank • any deformation of tank lid • tightening butterfly nut and bolt • air leak from tank lid packing 	grease	supply period	grease	every 1,200 operating hours
grease	supply period					
grease	every 1,200 operating hours					

8. Problems and remedies

Important

Ask the distributor or the shop who sold it to you about ☆ marked items.
If they are not done properly, it can cause poor performance.

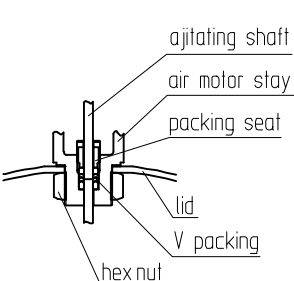
Problems	Causes	Research	Remedies
① Pressure does not increase (in tank) .	① Air cock is open.	① Open exhaust valve and check exhaust of air.	① Open air cock fully.
	② Exhaust valve and butterfly nut are not tightened.	② Air exhausting sound is heard (not heard when normal)	② Close fully.
	③ Pressure gauge is damaged.	③ Air exhausting sound is heard	③ Replace with new one ☆
② Paint does not come out.	① Compressed air is not supplied.	① Open exhaust valve and check exhaust of air.	① • Open air cock fully. • Tighten air regulator.
	② Air cock is open.	② -ditto-	② -ditto-
	③ Paint runs out.	③ Remove lid and inspect inside.	③ Replenish paint.
	④ Air intake filter is clogged.	④ -ditto-	④ Clean.
③ Air motor does not turn. (only PT-10DM(W), 20DM(W), 40DM(W), 60DM(W), 80DM(W))	① Air cock and air valve are not open.	① Check for air release from air motor exhaust hole.	① Open air cock and air valve fully.
	② Agitating shaft support band is stuck.	② Check if agitating shaft turns lightly by hand. ✖	② • Remove reason of sticking • Remove paint between agitating shaft and support band
	③ Agitating shaft and support band are not centered. ✖ Caution Fully tighten air valve of air motor and release compressed air before touching agitating shaft	③ -ditto-	③ Adjust shaft centering.
④ Paint leaks from agitating shaft hole lid.	① Packing is damaged or loosened.	① When compressed air is inside paint tank, air leaks from around agitating shaft. Check with soapy water.	① Tighten packing or replace parts. ☆ Lightly tighten packing seat. ✖ Caution Tighten packing when air motor turns slowly in case of air motor type. Overtightening weakens turning power of air motor.
			

Problems	Causes	Research	Remedies
⑤ Pressure rises even if handle of air regulator is loosened.	① Damage to valve set of air regulator.	① Remove rear lid, valve set and check.	① Replace valve set. ☆
	② Dust is stuck between valve set and seal.	② -ditto-	② Remove dust.
⑥ Air exhausts from cap when handle of air regulator is loosened. Air exhausts from air release hole when handle is loosened. This is because air release mechanism works. It is not a problem.	① Damage to tapered surface of diaphragm bolt	① Remove cap, diaphragm bolt and check.	① Replace diaphragm bolt ☆
	② Dust is stuck to tapered surface of diaphragm bolt.	② -ditto-	② Remove dust.
	③ Damage to diaphragm	③ Air exhausting sound is always heard from air release hole of cap.	③ Replace diaphragm. ☆

air regulator

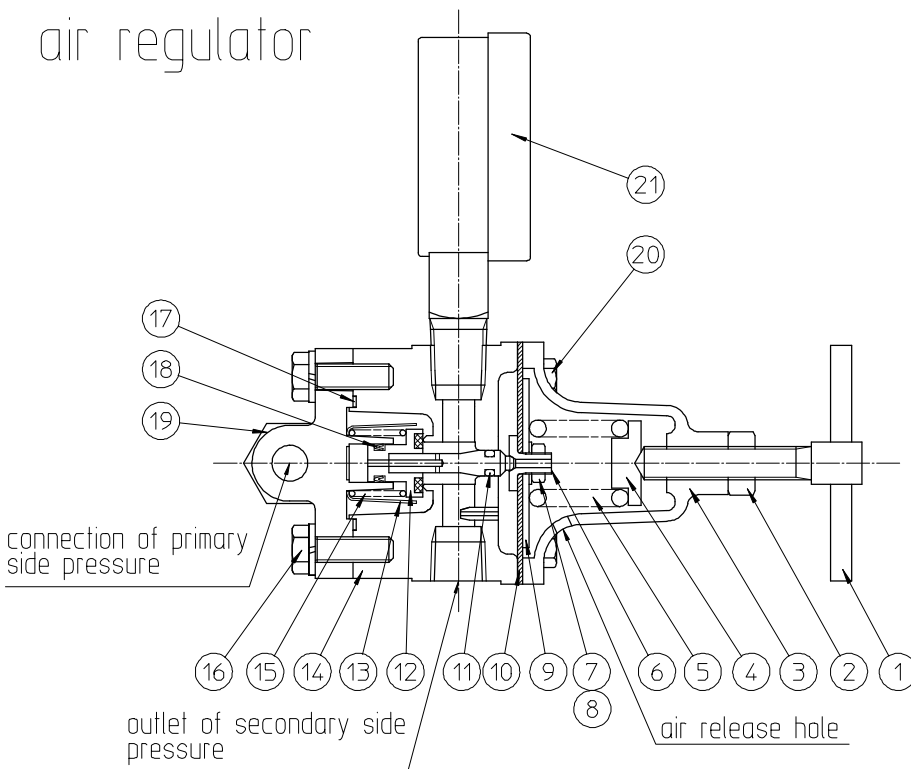

No.	parts name
1	handle
2	hex. nut
3	cap
4	spring holder
5	adjusting spring
6	diaphragm bolt
7	hex. nut
8	washer
9	center plate
10	diaphragm
11	O ring
12	valve set
13	guide
14	body set
15	valve spring
16	tapping screw
17	packing
18	mini Y packing
19	rear lid
20	tapping screw
21	pressure gauge

9. Parts list

9-1. Paint tank(PT-10D(W)·20D(W))

Lid set of No. 1 includes 1-1~1-16

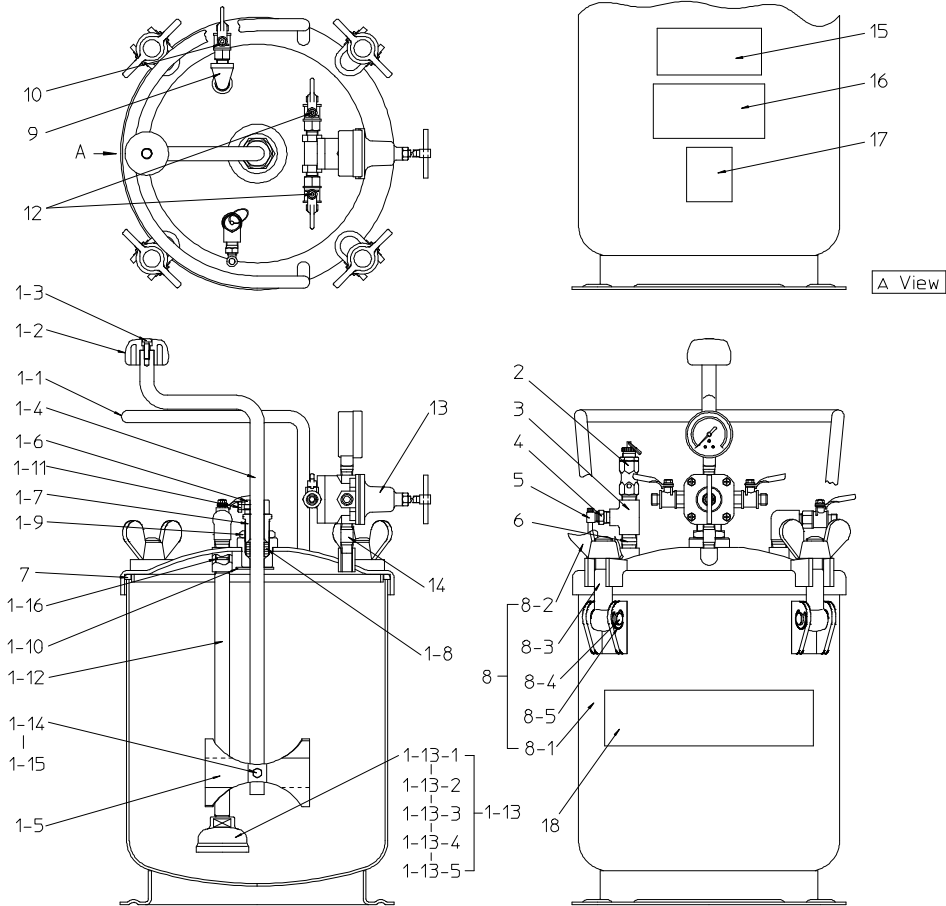

※marked parts are consumable parts.

No.	part name	quantity				No.	part name	quantity			
		10D	10DW	20D	20DW			10D	10DW	20D	20DW
1	lid set	1	1	1	1	3	reducing tee	1	1	1	1
1-1	handle lid set	1	1	1	1	4	exhaust valve body	1	1	1	1
1-2	handle	1	1	1	1	5	exhaust valve bar set	1	1	1	1
1-3	screw	1	1	1	1	6	long nipple	1	1	1	1
1-4	agitating shaft	1	1	1	1	※7	lid packing	1	1	1	1
1-5	agitating blade	1	1	1	1	8	tank set	1	1	1	1
1-6	shaft coupling	1	1	1	1	8-1	paint tank set	1	1	1	1
1-7	packing seat	1	1	1	1	8-2	butterfly nut	3	3	4	4
※1-8	packing set	1	1	1	1	8-3	eye bolt	3	3	4	4
1-9	hex. nut	1	1	1	1	8-4	eye bolt check pin	3	3	4	4
1-10	snap pin	1	1	1	1	8-5	snap ring	6	6	8	8
1-11	hex. bolt	2	1	2	1	9	street elbow	1	—	1	—
1-12	suction pipe	1	1	1	1	9-1	elbow	—	1	—	1
1-13	suction filter set	1	1	1	1	9-2	nipple	—	1	—	1
1-13-1	suction filter body	1	1	1	1	10	ball valve	1	1	1	1
1-13-2	suction filter support	1	1	1	1	12	ball valve	2	2	2	2
1-13-3	suction filter	1	1	1	1	13	air regulator	1	1	1	1
1-13-4	suction filter ring	1	1	1	1	14	long nipple	1	1	1	1
1-13-5	suction filter retainer	1	1	1	1	15	nameplate	1	1	1	1
1-14	hex. bolt	—	1	—	1	16	warning plate	1	1	1	1
1-15	spring washer	—	1	—	1	17	service nameplate	1	1	1	1
1-16	packing	—	1	—	1	18	corporate mark plate	1	1	1	1
2	safety valve	1	1	1	1						

9-2. Paint tank (PT-40D·60D·80D)

Lid set of No. 1 includes 1-1~1-15

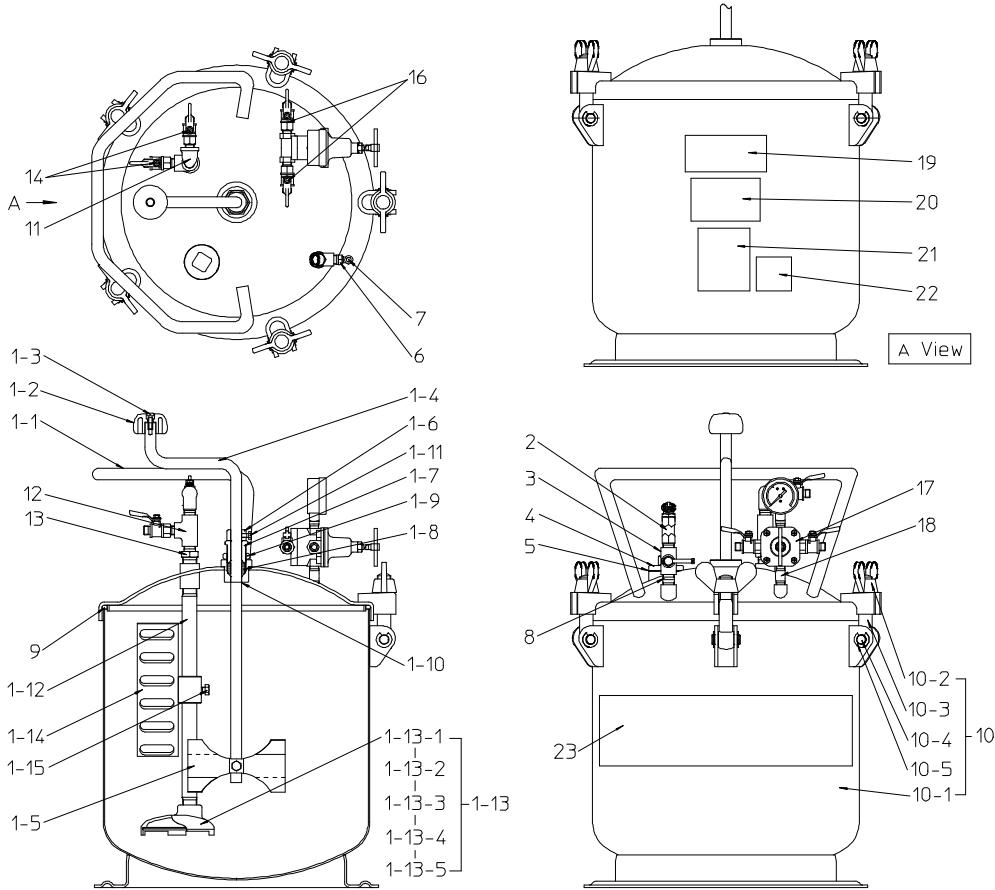

※Marked parts are consumable parts.

No.	part name	quantity			No.	part name	quantity		
		PT-40D	PT-60D	PT-80D			PT-40D	PT-60D	PT-80D
1	lid set	1	1	1	5	paint inlet packing	1	1	1
1-1	handle lid set	1	1	1	6	exhaust valve body	1	1	1
1-2	handle	1	1	1	7	exhaust valve bar set	1	1	1
1-3	screw	1	1	1	8	long nipple	1	1	1
1-4	agitating shaft	1	1	1	※9	lid packing	1	1	1
1-5	agitating blade	1	2	2	10	tank set	1	1	1
1-6	shaft coupling	1	1	1	10-1	paint tank set	1	1	1
1-7	packing seat	1	1	1	10-2	butterfly nut	5	5	5
※1-8	packing set	1	1	1	10-3	eye bolt	5	5	5
1-9	hex. nut	1	1	1	10-4	eye bolt check pin	5	5	5
1-10	snap pin	1	1	1	10-5	snap ring	10	10	10
1-11	hex. bolt	2	3	3	11	street elbow	1	1	1
1-12	suction pipe	1	1	1	12	tee joint	1	1	1
1-13	suction filter set	1	1	1	13	reducing nipple	1	1	1
1-13-1	suction filter body	1	1	1	14	ball valve	2	2	2
1-13-2	suction filter plate	1	1	1	16	ball valve	2	2	2
1-13-3	suction filter	1	1	1	17	air regulator	1	1	1
1-13-4	suction filter ring	1	1	1	18	long nipple	1	1	1
1-13-5	suction filter retainer	1	1	1	19	nameplate	1	1	1
1-14	turbulence plate set	1	1	1	20	warning plate	1	1	1
1-15	hex. bolt	1	1	1	21	caution place	1	1	1
2	safety valve	1	1	1	22	service plate	1	1	1
3	reducing tee	1	1	1	23	corporate mark plate	1	1	1
4	paint inlet	1	1	1					

9-3. Paint tank (PT-10DM(W)・20DM(W))

Lid set of No. 1 includes 1-1~1-24

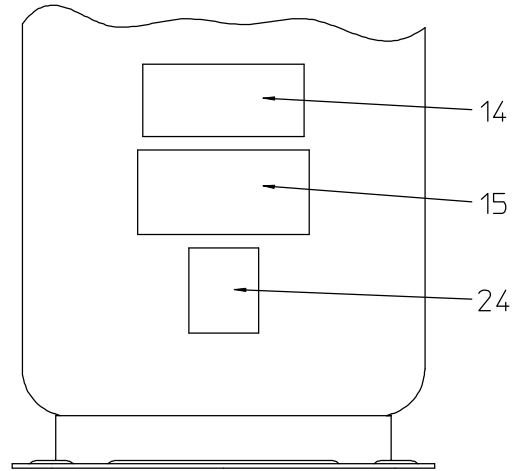
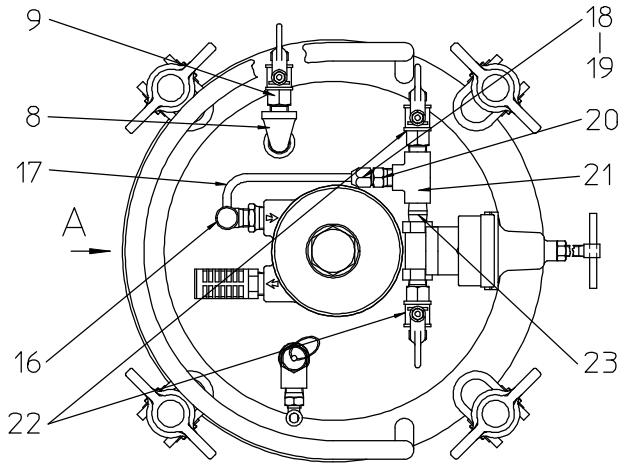

A View

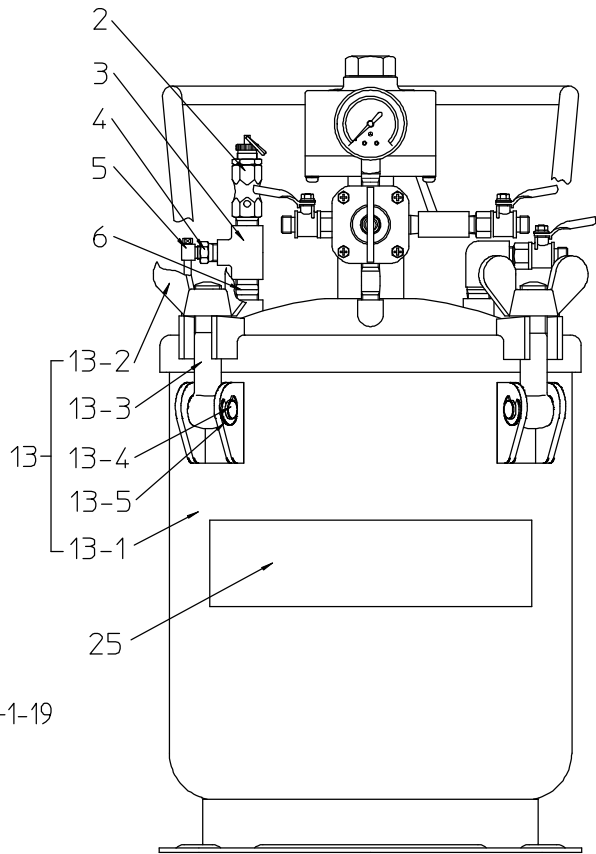
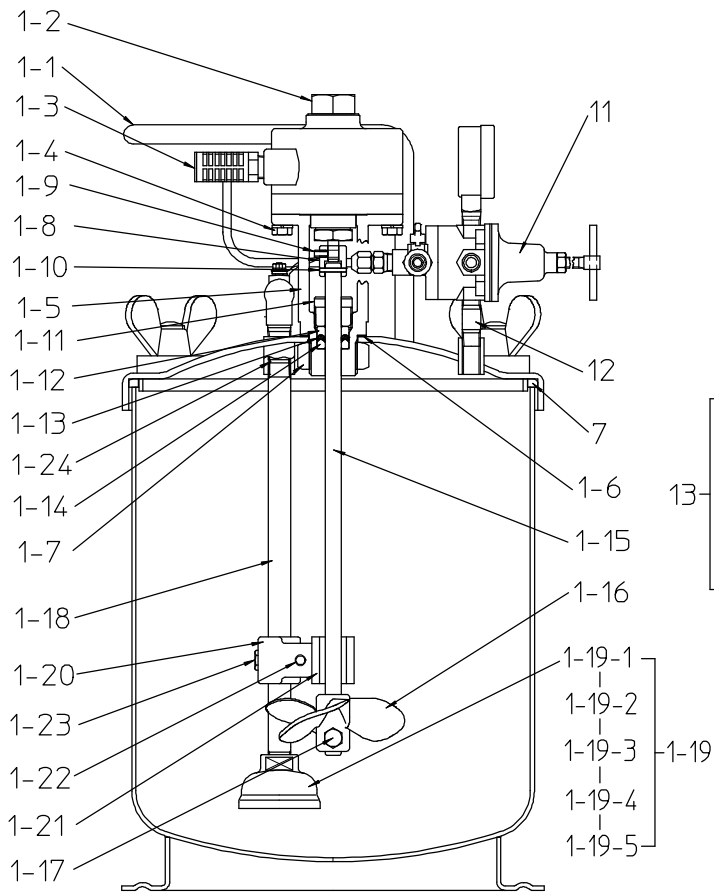

No. 1 lid set includes 1-1~1-24. ※marked parts are consumable parts.

No.	part name	quantity				No.	part name	quantity			
		10 DM	10 DMW	20 DM	20 DMW			10 DM	10 DMW	20 DM	20 DMW
1	lid set	1	1	1	1	2	safety valve	1	1	1	1
1-1	handle lid set	1	1	1	1	3	reducing tee	1	1	1	1
1-2	air motor	1	1	1	1	4	exhaust valve body	1	1	1	1
1-3	muffler	—	—	1	1	5	exhaust valve bar set	1	1	1	1
1-4	washer and bolt ass'y	—	—	2	2	6	long nipple	1	1	1	1
1-5	air motor stay	1	1	1	1	※7	lid packing	1	1	1	1
※1-6	packing	1	1	1	1	8	street elbow	1	—	1	—
1-7	hex. nut	1	1	1	1	8-1	elbow	—	1	—	1
1-8	shaft coupling	1	1	1	1	8-2	nipple	—	1	—	1
1-9	screw	2	2	1	1	9	ball valve	1	1	1	1
1-10	spring pin	1	1	1	1	11	air regulator	1	1	1	1
1-11	packing seat	1	1	1	1	12	long nipple	1	1	1	1
1-12	packing female adaptor	1	1	1	1	13	tank set	1	1	1	1
※1-13	V packing	3	3	3	3	13-1	paint tank set	1	1	1	1
1-14	packing male adaptor	1	1	1	1	13-2	butterfly nut	3	3	4	4
1-15	agitating shaft	1	1	1	1	13-3	eye bolt	3	3	4	4
1-16	agitating blade	1	1	1	1	13-4	eye bolt check pin	3	3	4	4
1-17	hex. bolt	1	1	1	1	13-5	snap ring	6	6	8	8
1-18	suction pipe	1	1	1	1	14	nameplate	1	1	1	1
1-19	suction filter set	1	1	1	1	15	warning plate	1	1	1	1
1-19-1	suction filter body	1	1	1	1	16	air valve	1	1	1	1
1-19-2	suction filter support	1	1	1	1	17	nylon tube	1	1	1	1
1-19-3	suction filter	1	1	1	1	18	joint nut	2	2	2	2
1-19-4	suction filter ring	1	1	1	1	19	joint ring	2	2	2	2
1-19-5	suction filter retainer	1	1	1	1	20	half union body	1	1	1	1
1-20	tightening band	1	1	1	1	21	tee joint	1	1	1	1
1-21	support band	1	1	1	1	22	ball valve	2	2	2	2
1-22	hex. bolt	1	1	1	1	23	barrel nipple	1	1	1	1
1-23	hex. bolt	1	1	1	1	24	service plate	1	1	1	1
1-24	packing	—	1	—	1	25	corporate mark plate	1	1	1	1

9-4. Paint tank (PT-40DM(W)・60DM(W)・80DM(W))

Lid set of No. 1 includes 1-1~1-25.

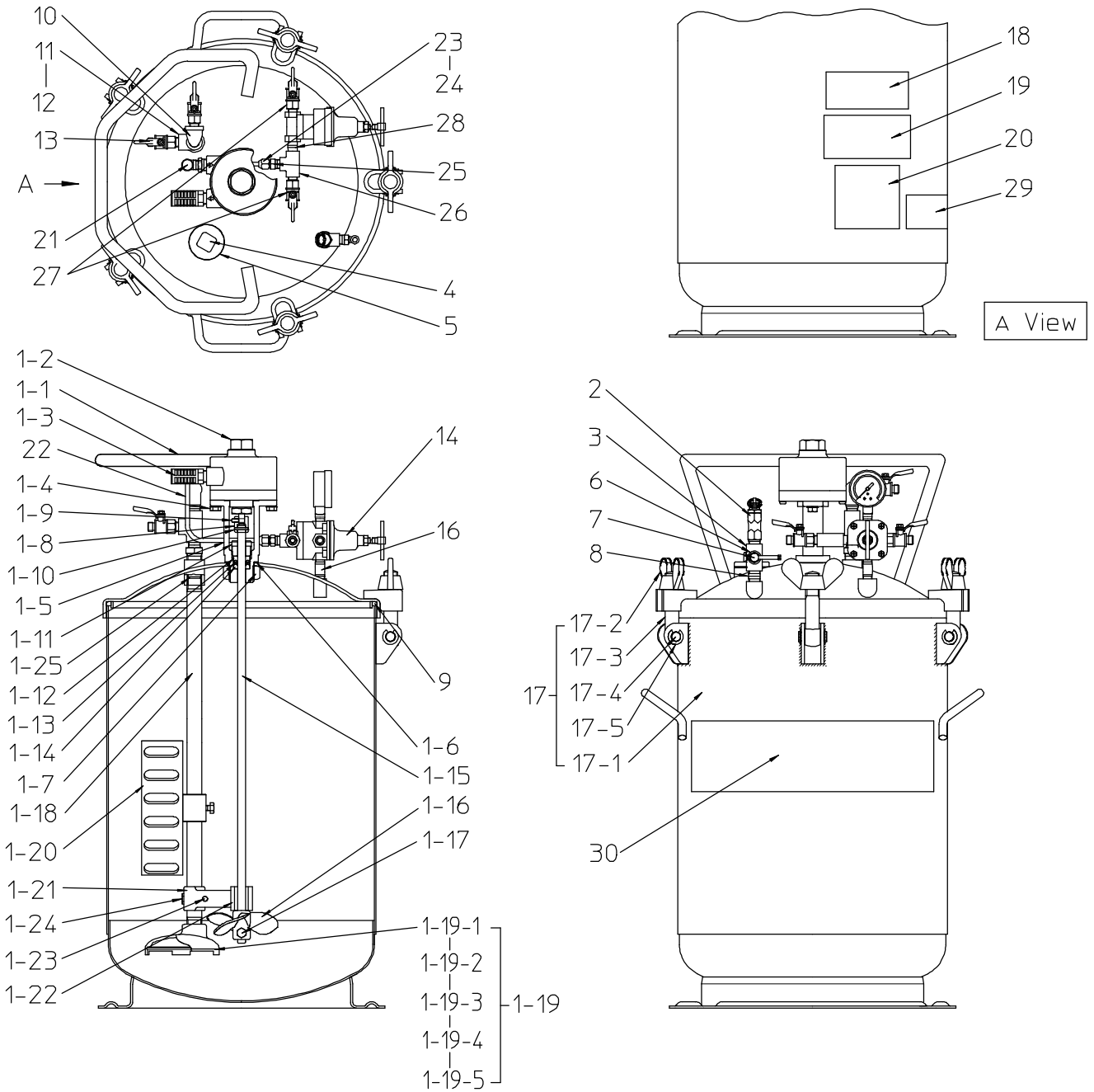

No. 1 lid set includes 1-1~1-25. ※marked parts are consumable parts.

No.	part name	quantity			No.	part name	quantity		
		PT-40 DM(W)	PT-60 DM(W)	PT-80 DM(W)			PT-40 DM(W)	PT-60 DM(W)	PT-80 DM(W)
1	lid set	1	1	1	4	paint inlet	1	1	1
1-1	handle lid set	1	1	1	5	paint inlet packing	1	1	1
1-2	air motor	1	1	1	6	exhaust valve body	1	1	1
1-3	muffler	1	1	1	7	exhaust valve bar set	1	1	1
1-4	washer and bolt ass'y	2	2	2	8	long nipple	1	1	1
1-5	air motor stay	1	1	1	※9	lid packing	1	1	1
※1-6	packing	1	1	1	10	street elbow	1	1	1
1-7	hex. nut	1	1	1	11	tee joint	1	1	1
1-8	shaft coupling	1	1	1	12	reducing nipple	1	1	1
1-9	screw	1	1	1	13	ball valve	2	2	2
1-10	spring pin	1	1	1	14	air regulator	1	1	1
1-11	packing seat	1	1	1	16	long nipple	1	1	1
1-12	packing female adaptor	1	1	1	17	tank set	1	1	1
※1-13	V packing	3	3	3	17-1	paint tank set	1	1	1
1-14	packing male adaptor	1	1	1	17-2	butterfly nut	5	5	5
1-15	agitating shaft	1	1	1	17-3	eye bolt	5	5	5
1-16	agitating blade	1	1	2	17-4	eye bolt check pin	5	5	5
1-17	hex. bolt	2	2	3	17-5	snap ring	10	10	10
1-18	suction tube	1	1	1	18	nameplate	1	1	1
1-19	suction filter set	1	1	1	19	warning plate	1	1	1
1-19-1	suction filter body	1	1	1	20	caution plate	1	1	1
1-19-2	suction filter support	1	1	1	21	air valve	1	1	1
1-19-3	suction filter	1	1	1	22	nylon tube	1	1	1
1-19-4	suction filter ring	1	1	1	23	joint nut	2	2	2
1-19-5	suction filter retainer	1	1	1	24	joint ring	2	2	2
1-20	turbulence plate set	1	1	1	25	half union body	1	1	1
1-21	tightening band	1	1	1	26	tee joint	1	1	1
1-22	support band set	1	1	1	27	ball valve	2	2	2
1-23	washer and bolt ass'y	1	1	1	28	barrel nipple	1	1	1
1-24	hex. bolt	1	1	1	29	service plate	1	1	1
1-25	packing (DMW)	1	1	1	30	corporate mark plate	1	1	1
2	safety valve	1	1	1					
3	reducing tee	1	1	1					



アネスト岩田株式会社

〒223-8501 横浜市港北区新吉田町 3176



ANEST IWATA Corporation

3176, Shinyoshida-Cho, Kohoku-Ku, Yokohama 223-8501, Japan

ご使用前の 注意

対象形式

PT-10D・10DM PT-20D・20DM
PT-40D・40DM PT-60D・60DM
PT-80D・80DM

この商品は容器内面・蓋裏面及び接液
部品に防錆油を塗布しておりますので、
シンナー等で洗浄してからご使用願います。

ご使用前に取扱説明書をよくお読み下さい

CAUTION

Intended model

PT-10D・10DM PT-20D・20DM
PT-40D・40DM PT-60D・60DM
PT-80D・80DM

Before using, make sure to wash inner face of
tank, back side of lid and fluid area of these
products by thinners or so.

If not done, anti-corrosion oil greasing these
areas will be mixed with paint.

Please read the Instruction Manual before using.

使用前的注意事项

型号

PT-10D・10DM PT-20D・20DM
PT-40D・40DM PT-60D・60DM
PT-80D・80DM

本商品出厂前，在容器的内面，盖内面和与
涂料接触的部分全部涂上了防锈油，请在使
用前用香蕉水等溶剂进行清洗。

请在使用前仔细阅读使用说明书。